



# Safari UT™ 250

---

## User Manual

12.8V / 20Ah / 256Wh Portable Power Unit



# WELCOME TO THE PRIDE



Our mission is to provide portable products that are safe, silent and renewable so you can use them wherever and whenever you want. We make products that are good for people and good for our planet. Period. We are driven by this passion. Lion Energy products are designed for everyday use – around the house, at work, on the go or during emergencies.

Our products are high-quality, lithium battery based solutions for everyday living. They range from small portable power banks and silent solar generators to RV batteries for auxiliary power and residential energy storage. We help you become energy independent with power to live life on your terms.

The Safari UT™ line is the latest in Lithium battery technology. It replaces traditional deep cycle lead acid batteries with the safest and longest lasting Lithium Iron Phosphate batteries.

*For latest info go to [www.lionenergy.com](http://www.lionenergy.com)*



# **READ THIS MANUAL IN ITS ENTIRETY BEFORE OPERATING THE UNIT.**

At Lion Energy we provide portable power that is safe, silent and renewable. Our products are used in emergencies and for work and play. Please read the user manual carefully before using the product and always take care when using this product. This product is not intended for use by young or infirm persons without supervision.

### **Attentions and Warnings**

1. Do not disassemble, resemble or repair the battery. Incorrect reassembly may cause combustion or electric shock.
2. If the battery is damaged, contact the place you purchased it.
3. Do not short-circuit the battery, use it near heat or water sources, or allow it to become wet.
4. Do not insert nails or other objects into the battery, strike it, or weld directly on the battery.
5. Do not use a badly damaged battery or operate it with damaged cables or charging adapters.
6. Do not operate this product in explosive atmospheres (i.e. flammable liquids, gases or dust) or set the unit on flammable materials (i.e. carpeting, upholstery, paper, cardboard).
7. Do not permit the battery to freeze. Never charge a frozen battery.
8. In case of skin or eye contact, rinse immediately with clean water and seek medical attention.
9. Do not keep using this product if it is damaged, waterlogged, distorted or broken.
10. This product contains lithium ion batteries. When it is worn out dispose it properly using local laws and regulations.

### **Package Contents**

Lion Safari UT™ 250: 1 pc  
User Manual: 1 pc

## Battery Pack Electrical Specification

#	Item	Parameter
1	Nominal Voltage (Works with 12V Systems)	12.8 (12V)
2	Technical Rated Capacity (Commonly Referred To As)	19.5Ah 20Ah
3	Minimum Capacity	≥19.5Ah
4	Internal Resistance	≤15mΩ
5	Standard Charging Current	10A
6	Max Charging Current	30A
7	Max Charging Volt	14.8V
8	Max Continuous Discharge Current	35A
9	Discharge Over Current Protection	50A 500us
10	Discharge Protection Voltage of Single Cell	2.5A
11	Operating Temperature	Charge: 32~113°F 45 ~ 85% RH Discharge: -4 ~ 130°F 45 ~ 85% RH
12	Storage Temperature	14 ~ 95°F 45 ~ 85% RH
13	Product Size	7.1"L x 3.0"W x 6.6"H
14	Product Weight	5.2 pounds

## Charging Recommendations and Limitations

The below diagram is a reference on how to connect four batteries in parallel in a 12V system. Before connecting, each battery must be independently fully charged. This battery should not be installed in series with another battery.

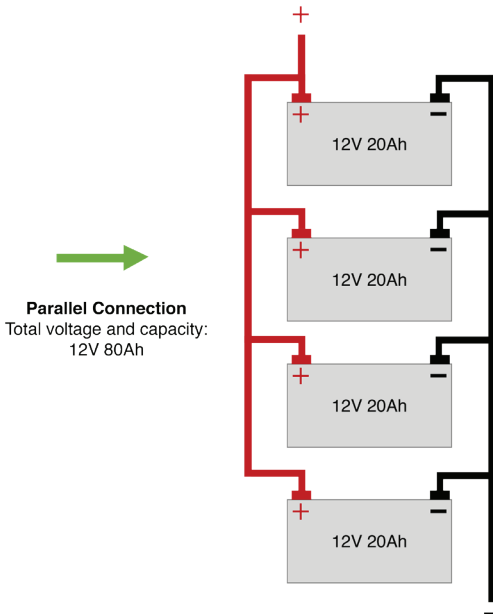

- The battery must be charged within a specified charging rate and the ceiling voltage of charging should be within the specification limits to avoid over charging. Over charging will lead to poor performance, mechanical instability, and possible safety issues.
- The battery should be used within specified discharge rate and the lowest voltage should be within the specification requirements to avoid over discharging. Over discharging will lead to poor performance, over heating, lead to battery failure, and possible safety issue.
- The battery must be used under required ambient environment according to specification. Too high or too low temperature may affect the performance of the battery.
- Constant charge/discharge rate not to exceed 0.5C to maximize the life span of the cell.
- Use the battery within 80% DOD to extend the service life of the cells.
- Battery must be fully charged and disconnected from all loads before storing for any amount of time.

## USER GUIDE

### Maintenance Suggestions

- For storage over one month, place the battery in a dry and ventilated room that is within the recommended storage temperatures.
- Do not store near corrosive material, fire, or heat sources.
- Discharge and charge the battery until full once every six months if not being used.
- In order to avoid over discharge, charge the battery periodically at the suggested battery storage voltage (13.3V, 80% SOC or greater).

### Warranty Repairs/Replacements

For repair or replacement, contact customer service at 1-385-375-8191. Do not ship unit until you receive a Return Merchandise Authorization (RMA) number from customer service at Lion Energy. Lion Energy will not be responsible for any shipping or handling damage.

#### Limited Warranty

This warranty for the unit is extended to the original purchaser or user, and it covers defects in materials and workmanship. The Safari UT250 has a limited 7 year warranty and will maintain a charge for up to 2,500 life cycles.

This warranty is invalidated if any of the following occurs, but not limited to:

- Failure to follow the instructions in the User's Manual.
- Accidental or unreasonable use, misuse, over charging or loading, or normal wear.
- Extended storage without recharging or repairs done by an unauthorized person or modification.
- Opening or modifying the battery casing.

This warranty is in lieu of all other express warranties. Lion Energy will not be liable for consequential or incidental damages. Changes or modifications not expressly approved by Lion Energy could void the user's authority to operate this device.

#### Service Address

Lion Energy  
www.lionenergy.com  
Address: 735 S. Auto Mall Drive  
American Fork, UT 84003  
Email: info@lionenergy.com  
Tel: 1-385-375-8191



## USER GUIDE



LIONENERGY™

### Warranty Information

Serial Number: \_\_\_\_\_

Purchase Date: \_\_\_\_\_



385.375.8191  
Monday - Friday  
9:00 AM - 5:00 PM



735 S. Auto Mall Drive  
Suite 200  
American Fork, UT 84003



info@lionenergy.com  
www.lionenergy.com  
@lionenergy

**Power Your Life.**